

Bi-directional Offset Lifting Bar

Danfoss Turbocor

Instructor - Dr. Gupta
Advisor - Dr. Hollis

Team 5

Yoel Bugin
Gabriel Omoniyi
Luke Leelum
Devin Stubbs
Coert Maraist

Outline

- Background
- Project Description
- Fall Recap
- Fabrication
- Challenges
- Prototype Testing
- Summary



Existing gantry and hoist system in the Chiller 3 Testing Room

Background

- Danfoss Turbocor is the world leader in oil-free centrifugal compressors used for cooling applications
- All compressors must be tested prior to distribution
- Since Chiller 3 was built Turbocor has developed a new line of VTT Compressors which have a greater height than can be installed with the current gantry and hoist system
- Turbocor asked Team 5 to develop a lifting bar that can be used with the current facility crane hoist and gantry



Project Description

- A better lifting system must be designed and implemented in order to conveniently install the compressor for testing
- Lifting bar to include:
 - Auto-leveling
 - Adjustable lifting positions
 - 1 Ton load capacity
 - Less than 500lb operating weight
 - OSHA Compliant

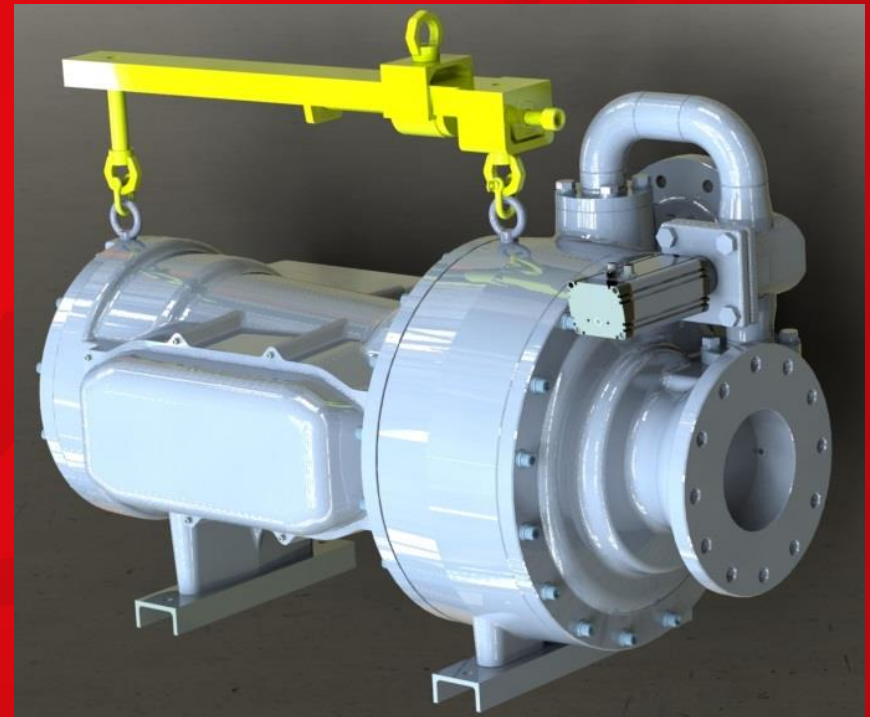

VTT Compressor with Team 5 Lift Bar

Fall Recap: Current Hoist and Gantry

- Crane hoist hangs below gantry
- Wasted space
- Can't be used for VTT Compressor

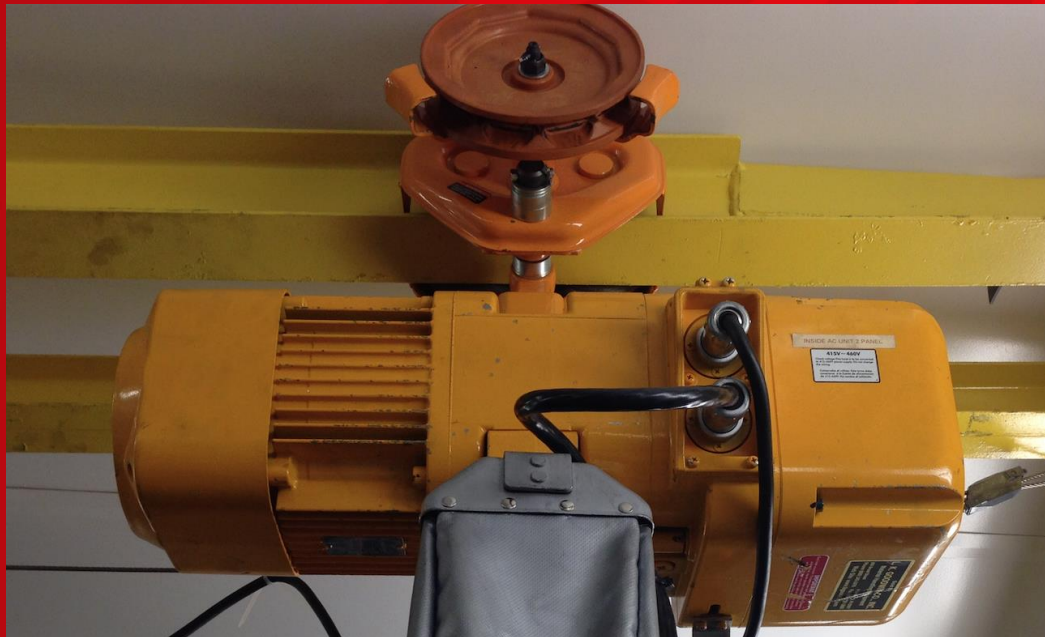

Fall Recap: Current VTT Lifting Bar

- Non-adjustable lifting hook positions
- Non-adjustable lifting point for variable center of gravity
- Suboptimal vertical height between lifting points



Fall Recap: Final Design

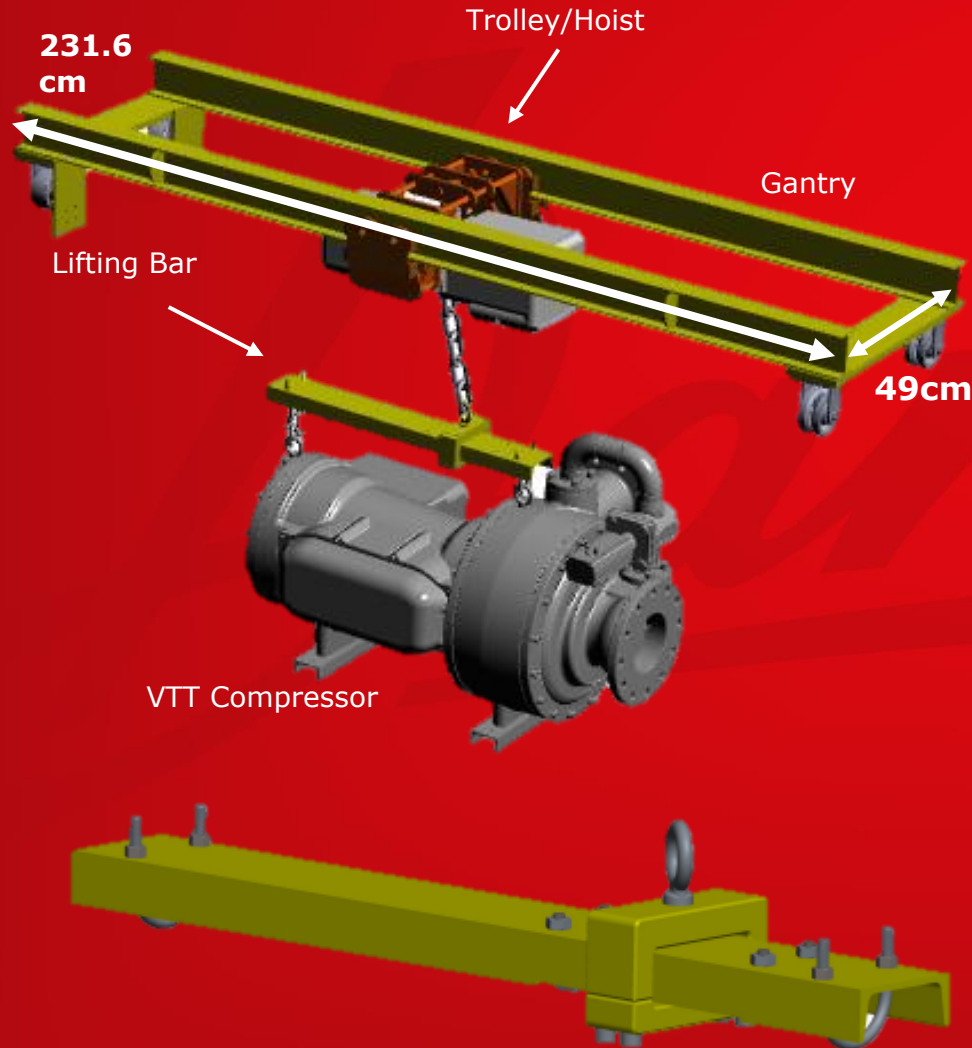

- Approved by Turbocor
- Increase vertical height of hoist (Approx. 177mm)
- Meets design requirements and OSHA standards
- Within budget constraints

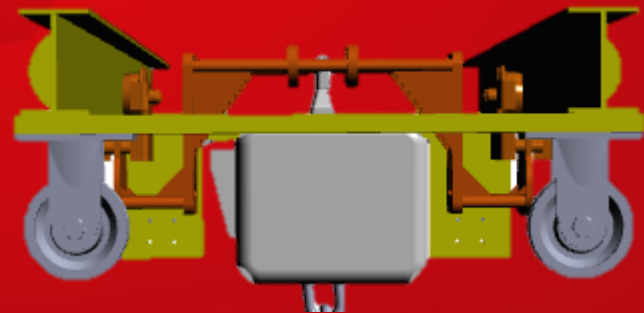

Fabrication: Overview

- Design Phase
 - Procurement Complete
 - Component FEA submitted and approved
 - Components and drawings altered per machining constraints
- Component Machining and Fabrication
 - All machining complete
 - Turbocor welded components per Team 5 specifications
- Assembly
 - Trolley Assembly Complete
 - Gantry requires casters, etc
 - Lifting bar to be assembled



Fabrication: Gantry & Trolley

- Assembly of Gantry and Trolley nearly complete
- Following OSHA Standards
 - Load tested at 1.25 load rating



Fabrication: Lifting Bar

- Lifting Bar components machined, ready for assembly
 - Lift Blocks milled to accommodate power screw
 - U-Channel decked and drilled
 - All other components require fasteners

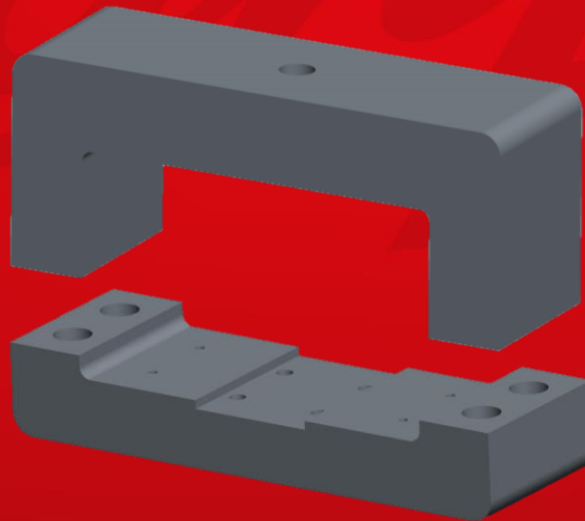

Challenges

- Material Purchased
- Machinery Tolerances
- Machining Allowances
 - Plan for mistakes
 - Design to mitigate them
- Unexpected machining issues
- Machine Shop Delays
- Scheduling of Fabrication



Prototype Testing

- All designed components must be load rated for 2000 lb
 - OSHA Standards require testing to be at 1.25 max load rating
 - All components tested at 2500 lb
- Gantry and Trolley to be tested using Civil Engineering Lab
- Lifting Bar
 - Testing method still undetermined
 - Hydraulic jack, come-along cable puller, tensile tester
 - Load cell to determine applied load
- Testing of adjustable lifting point
 - Dummy weight with realistic center of gravity
 - On site testing with VTT compressor

Gantt Chart

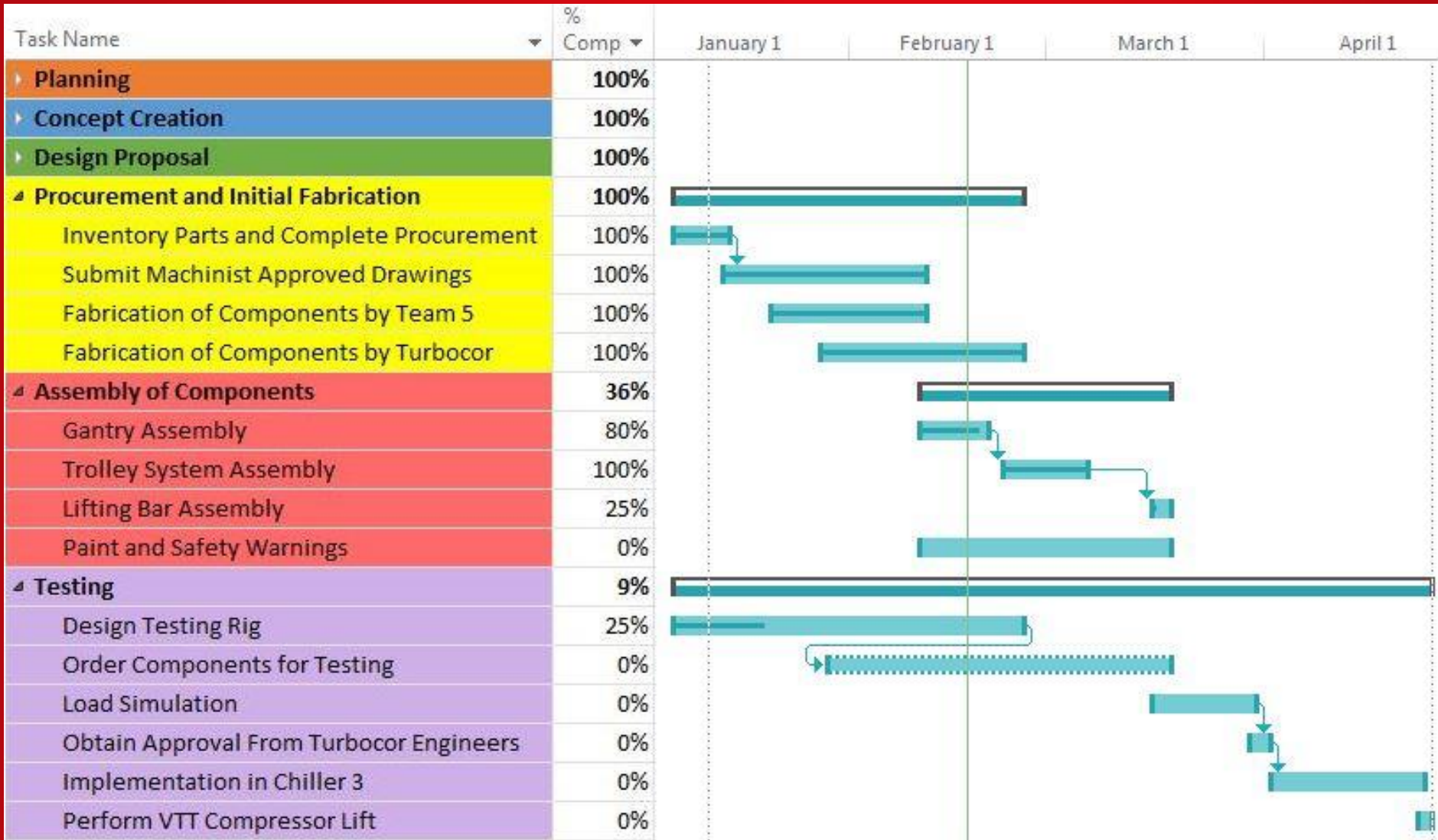

Summary

- Milestones Met
 - All parts delivered and inventoried
 - Drawings and FEA submitted and approved
 - Machining and Fabrication complete
- Future Work
 - Completed assembly of lifting bar and gantry
 - Finalize testing method and/or construct testing apparatus
 - Perform prototype load testing
 - User manual for each component
 - Onsite implementation at Turbocor

Questions?

More information available online at:

http://eng.fsu.edu/me/senior_design/2015/team05